



INFLIGHT FITNESS

CT-MFD

Multi-Fly/Delt



STANDARD FEATURES

- ✓ Dual ten position cams for varying ranges of motion for both pec fly and rear delt exercises.
- ✓ Five seat height positions.
- ✓ Ball bearing pivots.
- ✓ Compact design.

OPTIONAL FEATURES

- ✓ Steel shrouds powder coated and clear coated for a mar resistant lustrous finish.
- ✓ Standard 200 lb. tiered weight stack is upgradeable in 50 lb. increments to 300 lbs.

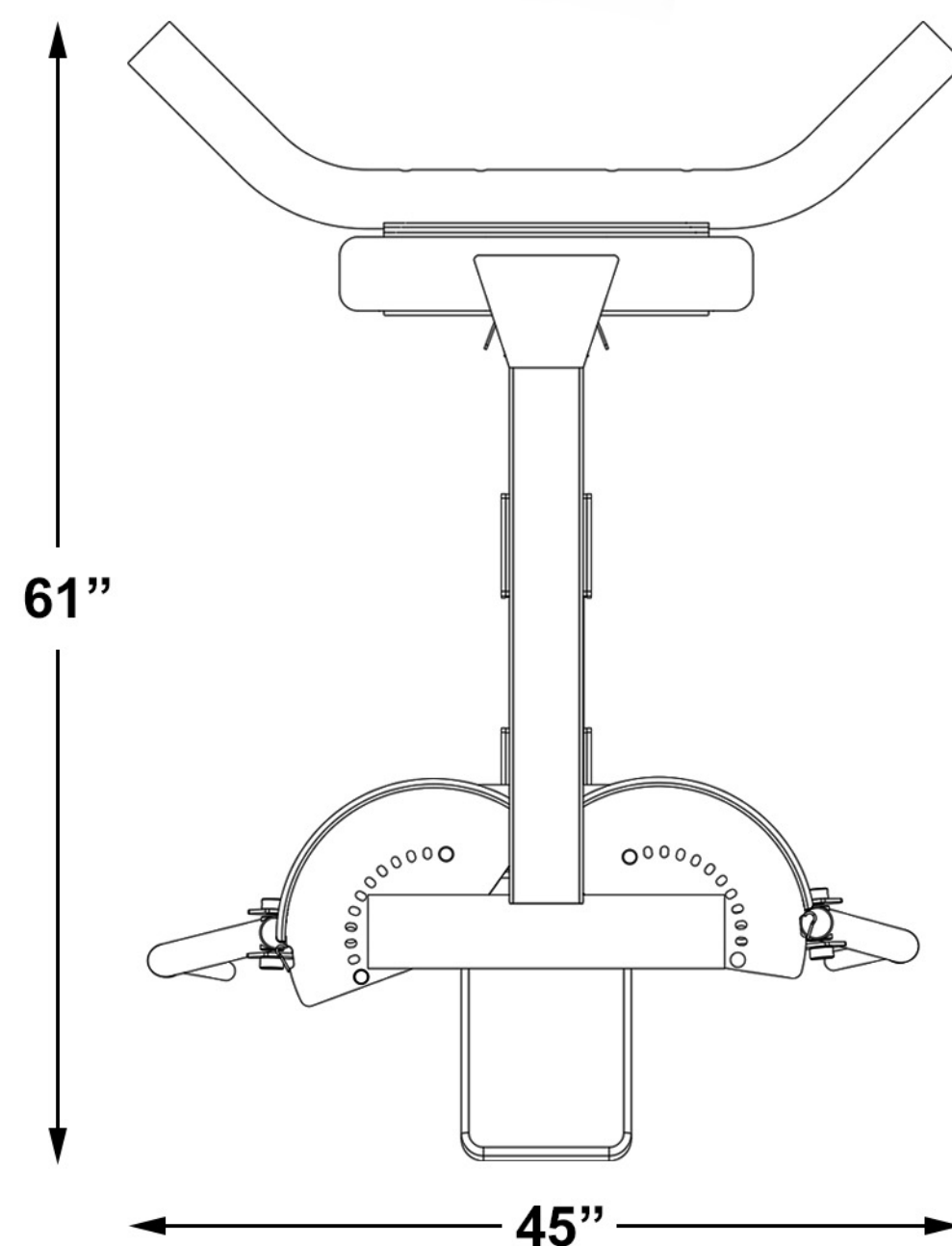

Visit www.inflightfitness.com to see our entire line of exercise equipment.

Lifetime limited warranty on frame, welds and weights; one year on cables and moving parts. See warranty for details.