



INFLIGHT FITNESS

CT-MIO

Multi-Inner/Outer



STANDARD FEATURES

- ✓ Padded thigh and ankle supports.
- ✓ Thirteen exercise start positions.
- ✓ Easy access weight stack.

OPTIONAL FEATURES

- ✓ Steel shrouds powder coated and clear coated for a mar resistant lustrous finish.
- ✓ Standard 150lb. weight stack is upgradeable to 225lbs.

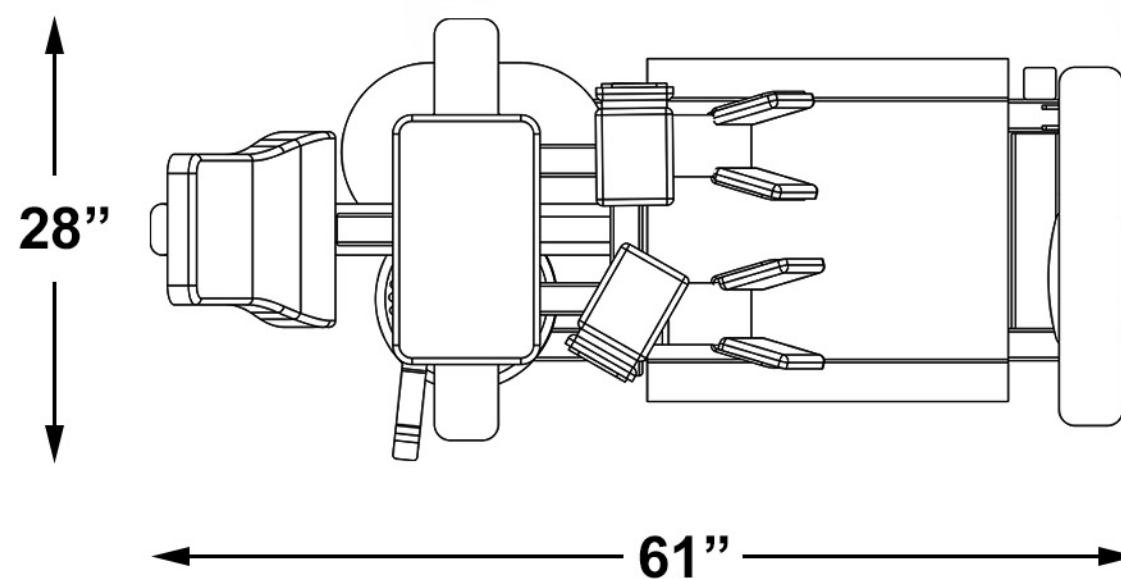

Visit www.inflightfitness.com to see our entire line of exercise equipment.