



INFLIGHT FITNESS

CCO

Cable Crossover



STANDARD FEATURES

- ✓ Adjustable pulleys for arm and leg exercises.
- ✓ Chin-up bar standard.
- ✓ Eighteen height adjustments.
- ✓ 4:1 cable pull on each handle.

OPTIONAL FEATURES

- ✓ Steel shrouds powder coated and clear coated for a mar resistant lustrous finish.
- ✓ Two standard 200 lb. tiered weight stacks are each upgradeable in 50 lb. increments to 300 lbs.

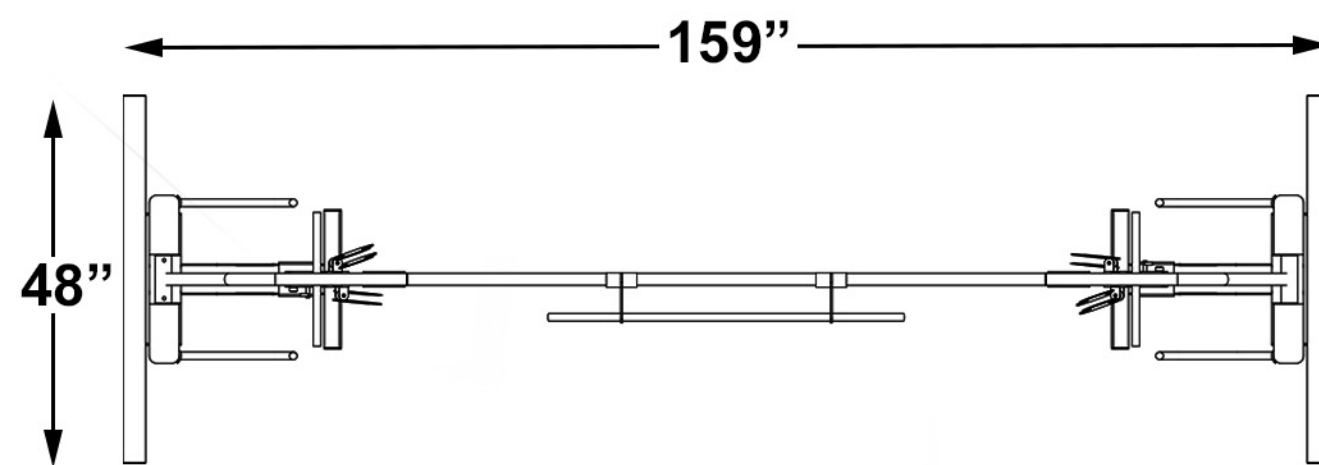

Visit www.inflightfitness.com to see our entire line of exercise equipment.

Lifetime limited warranty on frame, welds and weights; one year on cables and moving parts. See warranty for details.